



Land Development Guidelines for the Protection of Aquatic Habitat

These guidelines were produced by the Habitat Management Division of the Department of Fisheries and Oceans and the Integrated Management Branch of the Ministry of Environment, Lands and Parks.

The authors gratefully acknowledge all those people who contributed to the composition of these guidelines.

Compiled and edited by Barry Chilibeck, Department of Fisheries and Oceans,
and Geoff Chislett and Gary Norris, Ministry of Environment, Lands and Parks.

First Printing: May 1992

Second Printing: September 1993

**THIS DOCUMENT CONTAINS ONLY THE SECTIONS
NEEDED FOR THE API 1169 ICP EXAMS**

Section 3: Erosion and Sediment Control and Site Development Practices

SECTION 3

EROSION AND SEDIMENT CONTROL AND SITE DEVELOPMENT PRACTICES

Objective

Land development activities, such as clearing land, grading slopes, road building, and excavation and stockpiling of materials, can lead to the erosion of soils into nearby watercourses. These watercourses may contain fish and fish habitat, or flow into other streams that do. Increased surface runoff as a result of the development, due to lack of vegetation, infiltration and ponding, and the loose condition of disturbed soils leads to increased downslope transport of soils by the runoff. Even after the replacement and compaction of slopes and surfaces, soil erosion, gully and channel formation can occur. Sediments are composed of undissolved organic and inorganic materials ranging in size from microscopic particles to boulders, transported by flowing water. The finer material is carried suspended in the volume of water and is known as suspended sediment or suspended load. Larger material, generally consisting of coarse sand, gravels, and boulders, is carried along the channel bottom by the flow of water and is known as bed load. Understandably, on and offsite runoff management is a key factor in erosion and sediment control. Additionally, by preparing and covering disturbed soils, revegetating slopes and lining runoff channels, the amount of soil available to be eroded can be reduced. The objective of these erosion and sediment control guidelines is to minimize sediment inputs into fish habitat by reducing the potential for erosion, by stabilizing disturbed soils and intercepting sediment-laden runoff. Erosion and sediment control is extremely important because sediment can have severe negative impacts on all life stages of fish and their habitat. The following are examples of key fish and fish habitat impacts.

- Suspended sediment can settle on spawning areas, infill the intragravel voids and smother the eggs and alevins in the gravel.
- Bed load and settled sediments can infill pools and riffles, reducing the availability and quality of rearing habitat for fish.
- Suspended sediment can clog and abrade fish gills, causing suffocation or injury to fish.
- Suspended sediments can reduce water clarity and visibility in the stream, impairing the ability of juvenile fish to find food items.
- Settled sediments can smother and displace aquatic organisms (benthic invertebrates), reducing the amount of food items available to fish.
- Increased levels of sediment can displace fish out of prime habitat into less suitable areas.

Erosion and Sediment Control Methods

The key factors in erosion and sediment control are to intercept and manage off and onsite runoff. This limits the potential for soils to be eroded and form sediments in surface runoff. Runoff and surface erosion control is more effective and less expensive than sediment control with sediment control ponds only. Sediment control ponds have a limited capacity to remove sediments and are a last line of defense against sediment entering watercourses. Sound and sensitive development and construction practices are far more effective in complying with the objectives of these guidelines. Described below are the general principles of erosion and sediment control (ESC) and their application to land development activities (from Goldman, 1986).

Plan the development to the existing terrain and site conditions.

- Design and plan the development of roads, utilities and building sites with as little soil excavation and disturbance as possible.
- Design and plan development for the particular soil conditions and topography of the site.
- Confine construction to least critical areas and minimize impervious areas.
- Consider non-development of land in areas with extremely sensitive fish habitat values.

Schedule development to minimize risk of potential erosion.

- Where possible, plan construction activities during dry months of the year to avoid potential rain events and delays.
- Stage development to allow "green-up" or re-establishment of vegetation and minimize erosive areas.
- Halt construction during periods of heavy precipitation and runoff to minimize soil disturbance.
- Restrict vehicular and equipment access or provide working surfaces/pads.

Retain existing vegetation where possible.

- Minimize clearing rights-of-way and stripping of building sites.
- Avoid clearing and grubbing areas with sensitive soils.
- Consider aesthetics and retention of vegetation, including undergrowth.
- Physically mark clearing boundaries on the construction site.

Re-vegetate/protect denuded areas and bare soils.

- Seed or re-vegetate cut and fill slopes, and disturbed natural slopes.
- Cover temporary fills or stockpiles with polyethylene sheeting or tarps.
- Use mulches and other organic stabilizers to minimize erosion until vegetation is established on sensitive soils.
- Plan seeding and planting to allow establishment before end of growing season

Divert runoff away from denuded areas.

- Minimize flow over bare areas by diverting overland flows away from development areas.
- Isolate cleared areas and building sites with swales to direct runoff.
- Avoid steep slopes below rills and gullies.
- Retain natural drainage patterns wherever possible.

Minimize the length and steepness of slopes where possible.

- Erosion and soil loss is greater the longer and steeper the slope. Minimize both length and steepness of all slopes at engineering/planning stage.

Minimize runoff velocities and erosive energy.

- Maximize the length of flow paths for precipitation runoff to minimize energy of flow.
- Construct interceptor ditches and channels with low gradients to minimize secondary erosion and transport.
- Line unavoidably steep interceptor or conveyance ditches with filter fabric, rock or polyethylene lining to prevent channel erosion.

Design development for increased runoff.

- Design and engineer ditches and channels for post development flows.
- Construct stable, non-erodible ditches, inlet and outlet structures.

Retain eroded sediments onsite with erosion and sediment control structures.

- Utilize sediment traps and silt fences.
- Provide bed load clean-outs at culverts and ditches.
- Construct and operate sediment control ponds.

Plan, inspect, and maintain erosion and sediment control structures.

- Develop and follow a maintenance and inspection schedule as part of the development plan.
- Stockpile the required erosion/sediment control materials: filter cloth, rock, seed, drain rock, culverts, staking, matting, polyethylene, used tires, etc.

Slope Protection

The following techniques should be employed to prevent the initiation of surface soil erosion and movement of sediments from slopes. The surface preparation applied to slopes can be determined by the type of material and grade of the slope. The measures used for erosion and sediment control on slopes are as follows.

- Application of surface protection.
- Application of silt fences.
- Design and installation of interceptor ditches.
- Application of other land development erosion control features or approved erosion control measures.

Conditions of implementation of these erosion and sediment control measures for slopes should be as follows.

- In dry conditions, all cut/fill and cleared natural slopes and surfaces should have erosion controls implemented within 14 days.
- In wet conditions, erosion control should be implemented immediately on completion of the grading operations of the worked area.
- Slopes exceeding 3.0 meters in height and steeper than 2H:1V should be reviewed by a Professional Engineer to assess slope stability, erosion, and drainage control requirements.

The photographs in Figure 3.1 illustrate some prominent features of both slope and surface erosion control structures.

Temporary Slopes

Protection for a duration up to 6 months. Temporary slope preparations are determined by subgrade type (below) and slope/erodibility.

- **Bed Rock/Hard Glacial Till Subgrade:**
Slopes may be left exposed.
- **Silt, Sand, Mixed Sand/Gravel Subgrade:**
Temporary surface protection.
- **Organic or Top Soil Subgrade:**
Temporary surface protection.
- **Coarse Gravel/Cobble Subgrade:**
Slopes may be left exposed. No surface protection unless erosion develops.

Figure 3.1 Surface and Slope Erosion and Sediment Control Applications



Long Term or Permanent Slopes

Protection for a duration exceeding 6 months. Permanent slope preparations are determined by subgrade type (below) and slope/erodibility.

- **Bed Rock/Hard Glacial Till Subgrade:**
Slopes may be left exposed.
- **All Other Subgrade Types:**
Permanent surface protection.

Soil Excavation Stockpiles

All soil which is stockpiled for more than 7 days and less than 2 months should be covered with polyethylene or totally contained by a silt fence as a temporary measure to prevent erosion. Longer term stockpiles should be shaped to have side slopes no steeper than 1.5H:1V and remain covered with polyethylene, or have temporary surface protection applied.

Graded Areas

Temporary graded areas, such as housing lots, should be protected from erosion through the use of straw mulch and/or polyethylene tarps in non-traffic areas and a gravel cap in zones of construction traffic. Final graded or landscaped areas should have the appropriate permanent surface protection or landscaping in place as soon as possible.

Surface Protection

The purpose of these techniques is to absorb raindrop impact, reduce runoff velocity, improve infiltration, bind soil particles with roots, and protect the soil from the wind. The rapid establishment of a vegetation cover is generally recognized as the most cost effective form of surface erosion control. Protection of the soil surface with mulches or other materials will provide immediate erosion control until vegetation is established. When time is limited or vegetation establishment is not a goal, or weather conditions are unsuitable, the use of polyethylene sheeting or tarps is recommended.

Temporary Surface Protection

Surfaces and slopes less than 2H:1V use Seeding with Straw Mulch:

- Soil surfaces to be treated should be rough. Scarify to a maximum depth of 2.5 cm if necessary. Broadcast 100% fall rye seed at a rate of 50 kg/ha. Include 19-23-14 fertilizer at a minimum rate of 200 kg/ha.
- Cover the seeded area with at least 5 cm of straw, preferably applied with a blower. The straw should be held in place with a hydroseeder application of wood fiber mulch at 500 kg/ha and a tackifier at 40 kg/ha, or with netting.

Surfaces and Slopes up to 1H:1V use Seeding and Hydromulching:

- Soil surfaces to be treated should be rough. Scarify to a maximum depth of 2.5 cm if necessary. Broadcast 100% fall rye seed at a rate of 50 kg/ha. Include 19-23-14 fertilizer at a minimum rate of 200 kg/ha.
- Apply wood fiber mulch (designed for hydroseeding) at a rate of 2500 kg/ha together with tackifier at a rate of 60 kg/ha (or at the manufacture's recommended rate) with a hydroseeder to form a continuous blotter-like cover.

Highly Erodible Surfaces and Slopes use Seeding and Erosion Control Revegetation**Matting (ECRM):**

- Soil surfaces to be treated should be rough. Scarify to a maximum depth of 2.5 cm if necessary. Broadcast 100% fall rye seed at a rate of 50 kg/ha. Include 19-23-14 fertilizer at a minimum rate of 200 kg/ha.
- Roll the ECRM, a biodegradable pre-seeded erosion control mat, upon the soil surface and anchor it at the top. It needs to be adequately stapled to ensure it remains in place and in direct contact with the soil.

Highly Erodible Surfaces and Slopes use Polyethylene Cover

When immediate protection is needed or other protective techniques are not feasible, polyethylene sheeting or tarps can be used. It should be well anchored to resist wind (old tires are ideal) and prevent major leakage. Breaks in the cover should be repaired immediately. Polyethylene sheeting is not recommended for use on sites to be left idle for more than 2 months, unless weather conditions preclude the establishment of vegetation.

Permanent Surface Protection

Protection within 14 days for a duration exceeding 6 months. Options are identical to those described for temporary surface protection except for the following changes:

- The broadcast seed application should consist of fall rye at a rate of 20 kg/ha, plus the following mix (all percent by weight) at a rate of 60 kg/ha.

25% creeping red fescue	15% hard fescue
5% redtop	15% orchard grass
20% perennial ryegrass	10% alsike clover
10% white clover	
- The fertilizer should consist of standard commercial materials, with at least 60% of the nitrogen in the form of slow release urea. The rate of application should be based on laboratory soil analysis, with a minimum of 400 kg/ha of 19-20-12.
- All permanent surfaces and areas that are in final form and are to be vegetated as per the landscape plan, should be done as soon as practically possible (delays greater than 14 days, temporary slope and surface protection should be applied).

Interceptor Ditches

Interceptor ditches are structures designed to intercept and carry clean surface runoff away from erodible areas and slopes, reducing the potential surface erosion and limiting the amount of runoff requiring treatment. Alternatively, they can collect sediment contaminated runoff from slopes and carry it, without further erosion, to treatment areas or sediment ponds. Figure 3.2 shows typical installations of interceptor ditch structures as well as ditch lining types.

Design of Interceptor-Conveyance Ditches

- The location and access to interceptor ditches should be determined following analysis of the topography, the existing or planned drainage pattern and subgrade conditions. They should be laid out, following contours if possible, and constructed during initial clearing.
- Interceptor ditches should be located along the uphill boundaries of development sites, the uphill sides of major cut and fill slopes, to intercept and convey overland runoff.
- Interceptor-conveyance ditches should be designed to take a 2 year (1:2) storm runoff flow with 0.3 meters freeboard. Sideslopes should be no steeper than 1H:1V.

Construction of Interceptor Ditches

The construction and protection of the ditch should be based on the expected design flows, subgrade soil conditions, gradient and design life.

- **Bed Rock/Hard Glacial Till Subgrade:**
Ditches can remain unlined.
- **Silt, Sand, Mixed Sand/Gravel, or Organic Subgrade:**
Ditches should be lined with 0.6 mm polyethylene if it is overlapped 0.5 meters, bedded on non-angular material, and the top edges are anchored in small (0.30 meter deep) trenches along the top of the ditch. The subgrade should be free of any angular material.
- **Coarse Gravel/Cobble Subgrade:**
Shallow gradient ditches may remain unlined. Steep gradient ditches should be armoured or lined with polyethylene as above.
- **Steep Gradient and/or Large Volume Ditches:**
Steep gradient and/or ditches carrying a large volume of water will require full rock armouring to design water levels to prevent scour and bank erosion.
- Interceptor ditches may require energy dissipators at changes in grade and elevation, as well as armouring at changes in direction. Energy dissipators may be weirs built of broken rock, gabions, concrete or timber. The location and design of energy dissipators should be done by a Professional Engineer.

Figure 3.2 Typical Interceptor Ditch Construction and Application

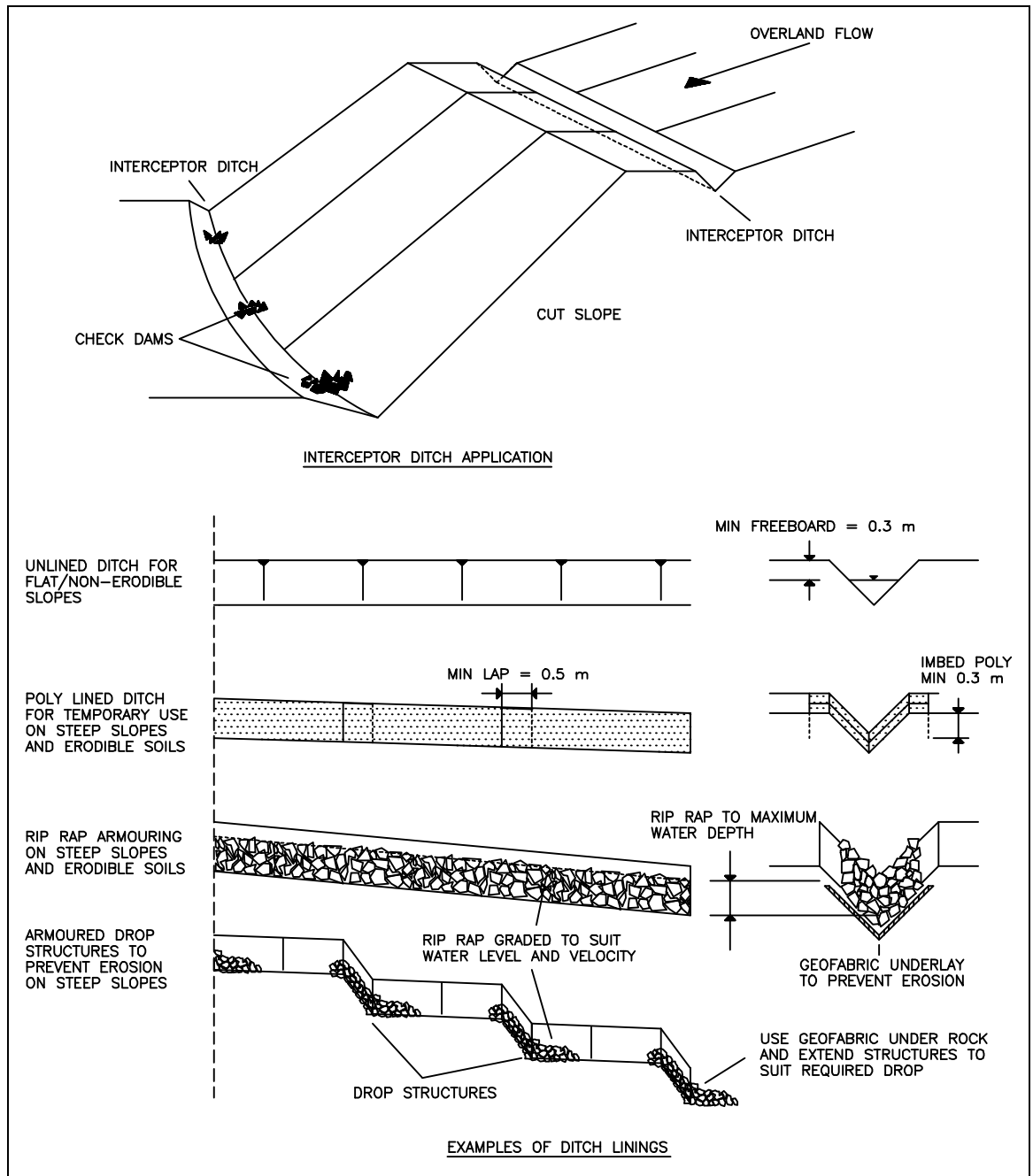

- Excavated bed load traps or pools formed by gravel berms can be constructed to collect eroded material. They should be located downstream of points of sudden reduction in gradient. They should be cleaned out after heavy rainfall or during periods of sustained precipitation.
- Sideslopes should be seeded to reduce erosion and subsequent maintenance, and also to improve appearance, especially for permanent works. Temporary ditches should be filled and the area reclaimed when they are no longer required.
- A regular, permanent maintenance program is necessary to keep ditches in good working order. Silt has to be removed from silt traps, weirs may have to be adjusted or repaired, additional rip-rapping may be necessary. All ditches and structures should be inspected after heavy rainfall or during periods of sustained precipitation.

Silt Fences

Silt fences and related structures provide an effective filter for sediment-laden runoff from eroded slopes and surfaces. The fine openings do not allow the passage of sediment coarser than about 0.02 mm. Silt fences are effective boundary control devices, trapping the sediment close to the erosion source and preventing mobilization into runoff, but have a limited sediment retention capacity. Figure 3.3 illustrates some typical applications using silt fences for erosion control, and design parameters.

- Silt or filter fences should be installed on the lower perimeter of slopes (lower 1/3 to 1/2 of site) and areas where the erodibility is high and/or it is desirable to contain waterborne movement of eroded soils. Such areas include the bottom of cut or fill slopes, material stockpiles and disturbed natural areas.
- Filter fabric or geotextile may be a pervious sheet of slit film woven polypropylene, nylon, polyester, or ethylene yarn, having the following properties.
 - Minimum Filtering Efficiency 90%.
 - Minimum Flow Rate 0.012 m³/m²/minute.
 - Minimum grab tensile strength 700 N.
 - Minimum equivalent opening size 0.15 mm (median 0.21 mm).
- If standard strength filter fabric is used it must be backed by a wire fence supported on posts not over 2.0 meters apart. Extra strength filter fabric may be used without wire fence backing if posts are not over 1.0 meters apart. Fabric joints should be lapped at least 0.15 meters and stapled. The bottom edge should be anchored in a 0.30 meter deep trench, or some equivalent manner, to prevent flow under the fence.
- If the filter fabric decomposes or becomes ineffective, it must be replaced and the fence repaired.

Other Erosion Control Measures

The following sediment and erosion control structures are used to varying degrees to mitigate onsite erosion and control runoff.

Sediment Traps

Sediment traps should be installed at the lowest point on each lot prior to excavation and construction on the site. Swales or ditching should convey surface runoff to these traps prior to pumping or discharge from the site. Sediment traps operate like small sediment control ponds by controlling the discharge of sediment offsite.

Swales

Swales are effective at re-directing surface runoff away from erodible sites and reducing the amount of sediment laden runoff generated onsite. They should be constructed of clean, non-erodible granular material in 0.3 meters high ridge with a low gradient to prevent scouring and further sedimentation.

Gravel Berms, Small Silt Fences, Check Dams and Bale Structures

These should be installed in overland flow paths, swales and other possible locations of concentrated flow to arrest migration of erodible soils. Their number and spacing will depend on the nature of the construction operations. They are effective at controlling sediment close to its source.

Culverts

Groundwater seepage and other small flows can be contained and flumed away from sensitive slopes and cut banks to prevent erosion of toe areas and maintain slope stability. They are also effective for conveying flows down steep slopes where it would be impossible to convey through an open channel.

New Drainage Systems

Storm sewer and drainage systems should have their inlets blocked, or should have sediment traps installed at inlets until all work is complete. During curb construction, roadside drainage should be temporarily controlled in swales and directed into the storm sewer system at suitable locations provided with sediment traps. Systems can be utilized for conveying flows to sediment control ponds.

Sediment Control Ponds

Design of Sediment Control Ponds

Sediment control ponds are the last line of defense before runoff is discharged from the development site. There is a practical limitation on the minimum size of particles that can be settled because of particle size, settling characteristics, residence time and land area available for sediment ponds. This minimum size has been set at 0.02 millimeters (mm) which equals a settling velocity (v_s) of 0.02 cm/s @ 0°C. Even at design flows, many particles smaller than 0.02 mm will pass through the sediment control pond and can be deleterious to fish and fish habitat. This emphasizes the importance of minimizing the amount of site soils eroded and allowed to enter the sediment control ponds. The table below illustrates the increasing pond area (m^2) required per unit flow (m^3) to provide discrete particle settling using the following equation and assuming a specific gravity of solids = 2.65:

$$A = \frac{1.2Q}{v_s} \quad \text{Erosion and Sediment Control, USEPA, 1976.}$$

Table 3.1 - Required Surface Area and Overflow Rates for Discrete Particle Settling (m² pond area per m³ of flow)

particle classification	particle diameter (microns)	Water Temperature				
		0°C	5°C	10°C	15°C	20°C
coarse sand	1000	3	3	3	3	3
medium sand	500	8	7	6	5	5
fine sand	250	40	33	28	23	19
coarse silt	62	621	528	455	396	464
medium silt	31	2486	2111	1819	1583	1389
fine silt	16	9332	7924	6829	5943	5213
very fine silt	8	37327	31697	27318	23773	20853
coarse clay	4	149310	126788	109271	95091	83413
medium clay	2	597239	507153	437085	380364	333653
fine clays	1	2388956	2028611	1748342	1521458	1334612

The proper design and operation of settling facilities in no way removes the responsibility of the proponent from achieving the site runoff water quality objectives .

Where the use of gravity settling will not provide the required effluent quality, or where lack of space does not permit provision of such facilities, the proponent may wish to consider the use of mechanical settling devices or chemical agents. The design requirements of such facilities are

beyond the scope of these guidelines and would require detailed plans prepared by a Professional Engineer. Such an installation would also require approval from MOELP - Environmental Protection Division for operation, maintenance, discharge and disposal of the residue.

Site Runoff Water Quality Requirements

Runoff water from the development site should contain less than 25 mg/liter of suspended solids (or non-filterable residue, NFR) above the back-ground suspended solids levels of the receiving waters during normal dry weather operation and less than 75 mg/liter of suspended solids above background levels during design storm events. However, where spawning areas are situated in the receiving waters, the storm runoff water discharged should not, at any time, increase suspended solids levels above background suspended solids levels in the receiving waters. Background suspended solids levels are the natural instream suspended solids or NFR levels measured upstream of the point of discharge in the watercourse. **If there is any question regarding the normal dry weather or design storm background level, DFO or MOELP staff should be contacted.**

Location and Number of Sediment Control Ponds

- Sediment control ponds should be located at the lowest practical point in the catchment area.
- The location, number, and size of ponds will reflect the area being developed at any one time, but a minimum of two (2) should be constructed.

Design Parameters for Sediment Control Ponds

- Design particle size 0.02 mm.
- Design pond area developed site 5 year (1:5) storm to calculate design area based on runoff flow and design particle or minimum of 1% of the total erodible area.
- Design horizontal velocity horizontal velocity which will not cause suspension or erosion of deposited material.
- Design hydraulic retention time minimum of 40 minutes.
- Design drawdown time 48 hours with no incoming flow or loss of accumulated solids.
- Overflow spill capacity developed site 1:10 year (1:10) storm event.
- Emergency spillway capacity developed site 1:100 year (1:100) storm event.

Dimensions and Capacities of Sediment Control Ponds

- Minimum effective flow path 5 times the effective pond width.
- Minimum freeboard 0.6 meters.
- Minimum free settling depth 0.5 meters above the top-of-sediment elevation.
- Minimum sediment storage depth 0.5 meters.
- Maximum interior sideslopes 2H:1V.
- Maximum exterior sideslopes 3H:1V.

Inlet and Outlet Structures of Sediment Control Ponds

- The inlet should distribute incoming flow across the width of the pond.
- Bypass piping or multiple ponds should be installed to allow pond servicing.
- A pre-treatment sump to remove coarse sediments is required.
- Only clarified surface water should be allowed to leave the pond.
- The dewatering drawdown holes should be protected with a granular filter to prevent formation of high velocity currents which could resuspend settled sediment.
- Discharge and conveyance of discharged pond flows should not cause erosion of natural drainage systems. Plastic culvert piping should replace ditching for temporary pond applications to limit disturbance in the FSZ.

Operation and Maintenance of Sediment Control Ponds

- Settled sediment should be removed after each storm event or when the sediment capacity has exceeded 33% of design sediment storage volume.
- Periodic inspection and removal of accumulated sediments and the required inspection and maintenance interval should be noted on the design drawings.
- Accumulated sediment removed during pond maintenance must be disposed of in a manner which will prevent its re-entry into the site drainage system, or into any watercourse.
- The tops of slopes or berms around sediment control ponds should be wide enough to provide a safe and stable work area where required for the operation of maintenance equipment and personnel and should be covered with crushed stone and/or turf stone to prevent damage to the structure, and loosening of soil which could wash into the pond.
- Multiple ponds or a single large superpond may be designed for a large development, but a minimum of two should be constructed for pond maintenance requirements.
- Sediment control ponds should be constructed during initial site development and maintained until all building construction and site grading work is completed. Sediment ponds may be retrofitted for use as stormwater detention ponds.

Stability and Public Safety of Sediment Control Ponds

- The stability of sideslopes for all earthen ponds should be confirmed by a Professional Engineer. All interior sideslopes in areas subject to water level fluctuations should be stable against pore water pressure during rapid drawdown. Exterior sideslopes should be structurally stable under all loads and hydraulic conditions.
- Suitable fencing and signage should extend around the perimeter of all ponds.
- Discharge risers greater than 450 mm diameter should have a trash rack to exclude large objects.
- See Figures 3.4 and 3.5 for typical sediment control pond design and details.

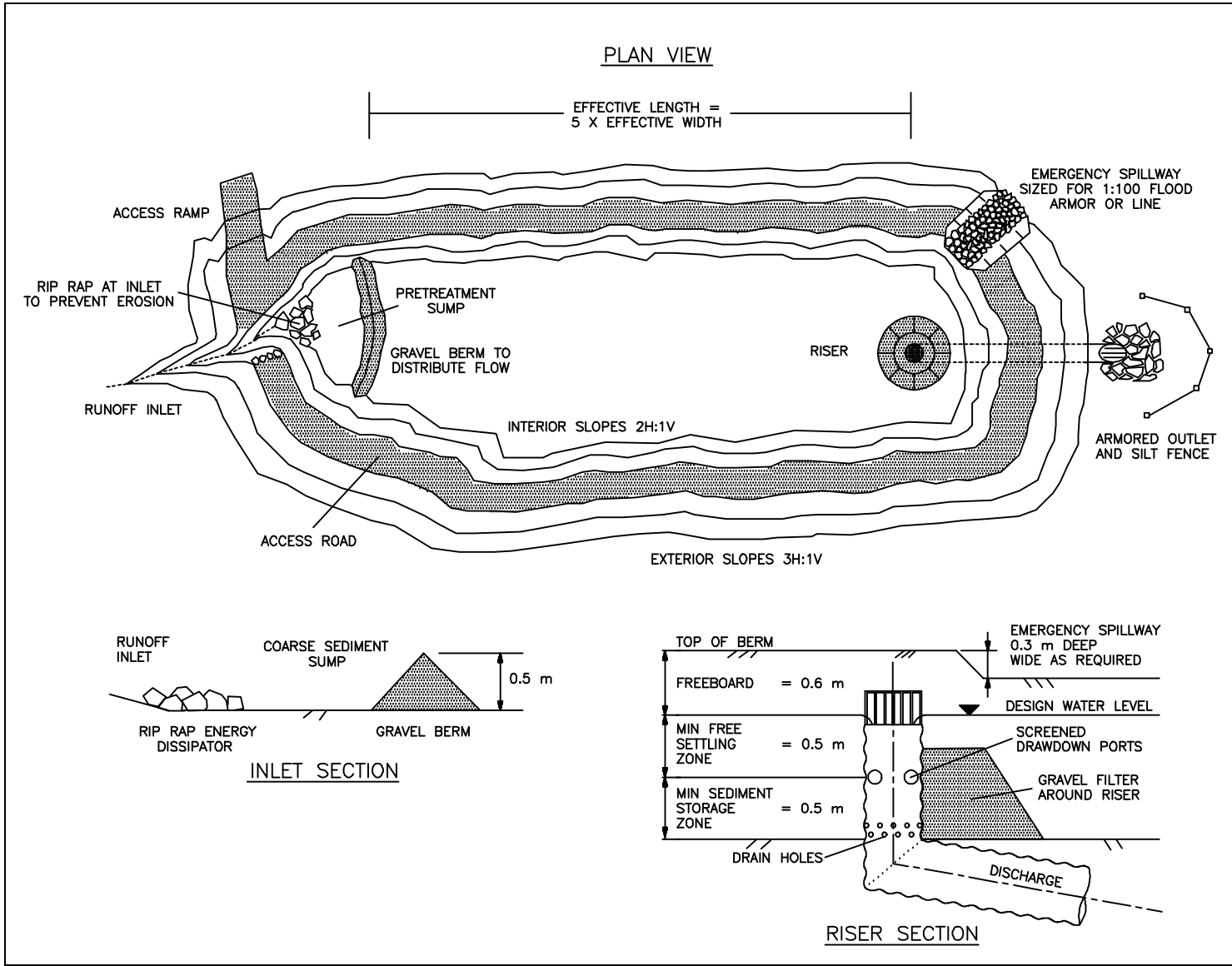

Figure 3.4 Sediment Control Pond Plan and Sections

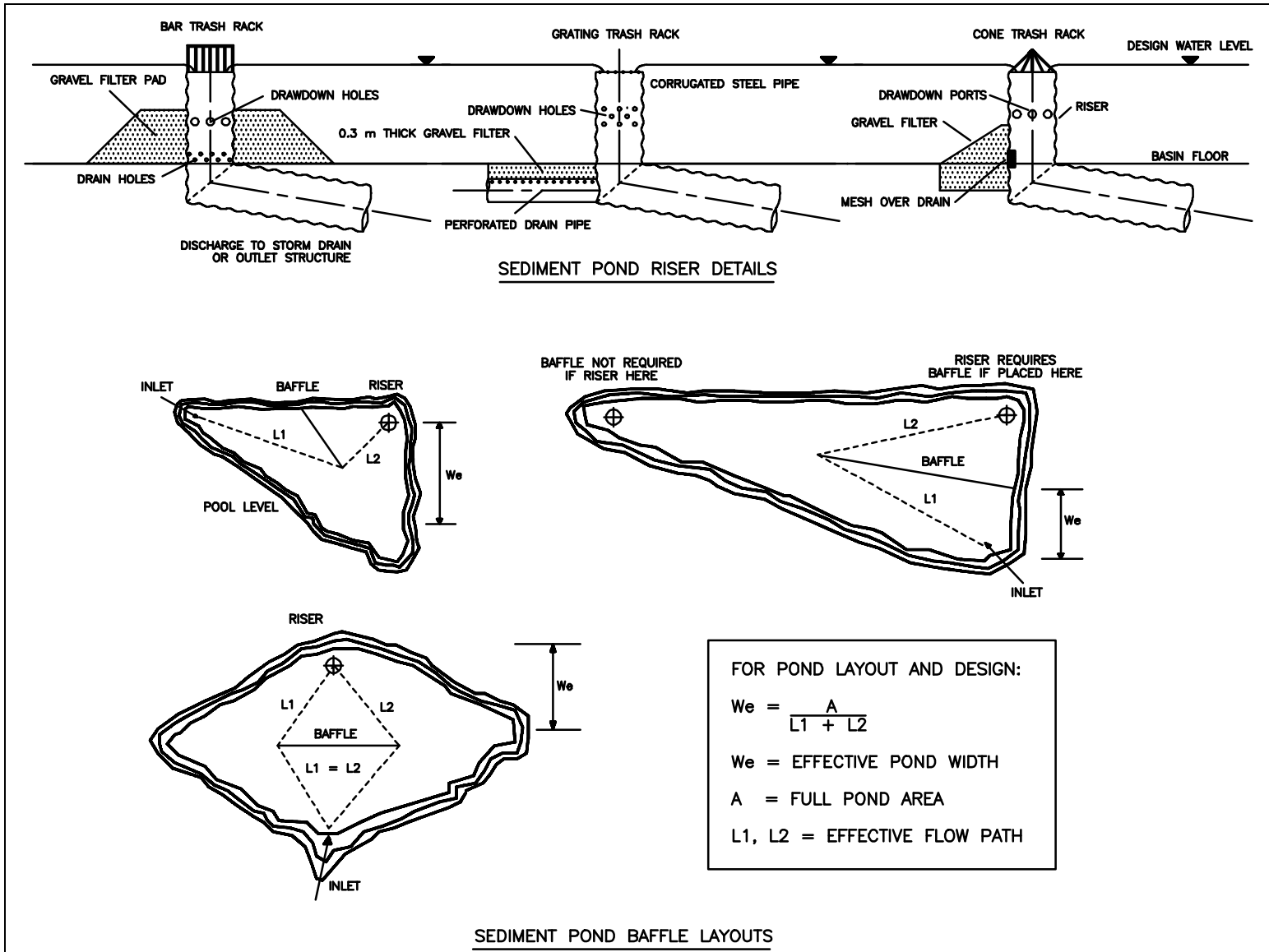

Figure 3.5 Sediment Control Pond Riser Details and Baffle Layouts

Guidelines for Control of Deleterious Substances on the Development Site

Common deleterious substances: sediments, raw and uncured concrete, mortar, glues, paints, lubricants, organic and inorganic contaminants, fuels and oils, can have detrimental or toxic effects on the aquatic environment and fish life (see Appendix I for definitions of "deleterious substances"). In most instances, the control of these substances can be dealt with through an awareness of their detrimental effects, the practice of good housekeeping (i.e. daily site clean-ups, use of disposal bins, etc.) on the development project site, and the proper use, storage and disposal of such substances and their containers. The following control guidelines should be reviewed by the developer and construction contractor to ensure no deleterious substances are released into fish habitat.

- Raw or uncured waste concrete and grouts should be disposed of by removal from the development site or by burial on the site in a location and in a manner that will not impact on a watercourse.
- Wash down waters from exposed aggregate surfaces, cast-in-place concrete and from concrete trucks should be trapped onsite to allow sediment to settle out and reach neutral pH before the clarified water is released to the storm drain system or allowed to percolate into the ground (approximately 48 hours).
- Fuels, lubricants and hydraulic fluids for equipment used on the development site should be carefully handled to avoid spillage, properly secured against unauthorized access or vandalism and provided with spill containment according to codes of practice.
- Fuelling and lubricating of equipment onsite should only be done after the equipment to be serviced is moved to a constructed service pad with a separate drainage collection system, as far as possible from detention or sedimentation facilities and leave strips.
- Any spillage of fuels, lubricants or hydraulic oils should be immediately contained and the contaminated soil removed from the site and properly disposed of in accordance with the federal Department of Environment - Environmental Protection (DOE/EP) and the provincial Ministry of Environment, Lands and Parks - Environmental Protection Division (MOELP/EPD) requirements. Any spills should be reported immediately to DOE/EP (phone: 666-6100) and MOELP/EPD (phone: 1-800-663-3456) for their counsel on appropriate clean up procedures.
- Hydraulic fluids for machinery used for instream work should be biodegradable in case of accidental loss of fluid.
- Waste oils and hydraulic fluids should be collected in leak-proof containers and removed from the site for proper disposal or recycling.

- The rinse and cleaning water or solvents for glues, paints, wood preservatives and other potentially harmful or toxic substances on the development site should be controlled so as to prevent leakage, loss or discharge into the storm drain system.
- Gypsum board wastes must be removed from the project site, preferably to a recycling facilities, or an approved disposal sites (disposal of gypsum board wastes by burying onsite is not permitted).
- Wood wastes, such as hog fuel, sawdust and wood chips, are not acceptable for fill material because of the potential release of toxic leachates from these wood wastes into the aquatic environment.
- Where land is being redeveloped and there is contamination of the site, those contaminants must be removed, disposed of, or otherwise neutralized, as prescribed by DOE/EP and MOELP/EPD, prior to proceeding with redevelopment of the affected lands. Potential mitigation and costs of contaminant removal are the responsibility of the land owner.

Guidelines for Development of Site Access

Significant release of sediments to the drainage systems and receiving waters can be caused by site access development and lack of control during land development and building construction activities. Included in the design of proper site access for minimizing potential impacts are:

- Construction site accesses should be restricted in number and to locations that will serve as permanent access after development.
- Access pads and roads should be constructed prior to site area development, and in a manner that will prevent the loosening of native subsoil.
- Access roads should be constructed or topped with a suitable coarse granular material with a minimum of fines and clays. Non-woven geotextile is recommended as a separation layer over the native subgrade. Organic topsoil should be stripped prior to road construction if possible, and removed offsite or stockpiled.
- Wood wastes, such as hog fuel, sawdust and wood chips, are not acceptable for the construction of access roads and support operations because of the potential release of toxic leachates from these wood wastes into the aquatic environment.
- Runoff from the access roads should be collected via interceptor ditches or swales. These flows should be routed to sediment ponds to allow the settling of sediments before release to the drainage system.
- Sweeping of loose soils from surfaced streets is recommended over water flushing to prevent soil entry into storm drains and the aquatic environment.

- Transport of excavated materials from the site should limit spillage on adjacent road surfaces and dropping of loose soils in the form of dust or mud from wheels, tracks and undercarriages of equipment.

Guidelines for Single Lot Development

The objectives during the development of an individual lot are to minimize erosion and release of sediment offsite by controlling the development and construction activities. Single lot erosion and sediment control measures include: planning the construction access; minimizing clearing and grading activities; control of excavated soil stockpiles; surface and slope preparations; and surface runoff control.

Site layout and Clearing

At the earliest stages, the individual lot development should be designed having regard to the general principles of erosion and sediment control, specifically:

- Design and layout of the building site to minimize impervious areas.
- Retain existing vegetation and ground cover where possible.
- Schedule construction to dry months of the year.
- Restrict vehicle access and provide a surfaced working area.
- Minimize clearing and stripping of set backs and easements.
- Clearly mark building area and clearing boundaries onsite.

Soil Erosion Control

Surface soil erosion from individual lots and building sites is generated mainly from soil excavations and graded areas. To minimize erosion onsite the following should apply:

- Cover temporary fills or soil stockpiles with polyethylene tarps.
- Re-vegetate or final landscape disturbed areas as soon as practically possible.
- Limit machine access and operation to prepared access areas only.

Drainage and Sediment Control

Site drainage features can usually incorporate sediment control features to limit the offsite transport of sediments directly into watercourses or into storm drainage systems that discharge into watercourses:

- Divert runoff away from cleared areas by use of swales or low berms.
- Utilize silt fences around soil stockpiles and sloped areas.
- Collect runoff into site sediment traps prior to discharge offsite.

Figure 3.6 illustrates a typical lot development plan with erosion and sediment control features .

Figure 3.6 Single Lot Development Erosion and Sediment Control Features

